

Guide to De-glazing procedure

Stellar knock-in glazing bead removal procedure

When it is required to remove the Stellar knock-in glazing bead, the following procedure must be followed to avoid damage to the bead and/or frame.

Tools required:



Don Carlos
pallet knife



Nylon
mallet

STEP 1

With the Don Carlos pallet knife ensure that the sharpened chamfer is pointing towards the glazing as shown below.

Using the nylon mallet, carefully tap the pallet knife blade into the gap between the bead and frame, near the bead end, until the blade bottoms out.

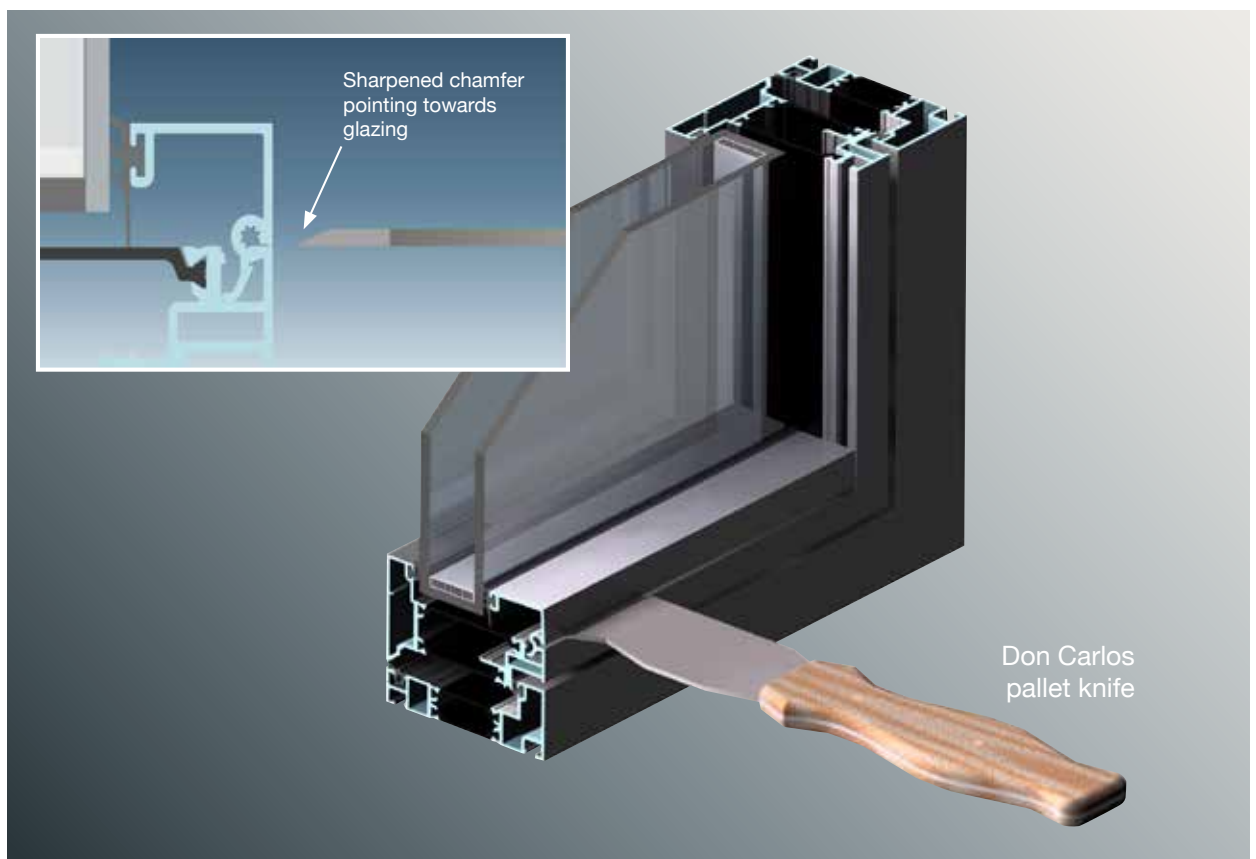

STEP 2

Carefully lever the knife **TOWARDS THE GLAZING** as shown below.
DO NOT lever in the opposite direction away from the glazing.
DO NOT twist knife.

Repeat this procedure working along the bead until the whole bead is dis-engaged from the frame. Remove bead.

Repeat on remaining beads taking care to note location from which beads were removed for later replacement.

